

**Electro-Module EM-50, EM-100, EM-180**  
**Electrically Released Permanent Magnet Brake Module**  
**EM-50-20FBB, EM-100-20FBB, EM-180-20FBB**  
**EM-50-20FBC, EM-100-20FBC, EM-180-20FBC**

P-273-5  
819-0529

**Installation Instructions**



**Vented**



**Enclosed Version Optional**



*An Altra Industrial Motion Company*

## Contents

Mounting a C-Faced Motor . . . . .	4
Bolting Two Modules Together . . . . .	5
Adjusting Air-Gap . . . . .	5
Mounting the Brake to a Motor . . . . .	7
Installing the Motor Mount Bracket . . . . .	7
Installing the Base Mount . . . . .	7
Mounting to a Reducer . . . . .	8
Mounting on the Input and Output Shafts . . . . .	8
Electrical Connections . . . . .	9
FB Brake Release Adjustment . . . . .	9
Burnishing . . . . .	10
Troubleshooting	
Electrical . . . . .	10
Mechanical . . . . .	11
Electrical Coil Data . . . . .	11
Mechanical Data . . . . .	11
Enclosed Electro-Module Option . . . . .	11
Warranty . . . . .	BC

**⚠ WARNING** Failure to follow these instructions may result in product damage, equipment damage, serious or fatal injury to personnel.

**⚠ WARNING** The equipment covered by this installation manual must be installed in accordance with these instructions. Failure to do so may damage the equipment and void the warranty.

Warner Electric Electro-Modules are designed to National Electrical Manufacturers Association (NEMA) standards. They can be mounted to common NEMA C-frame motors and reducers as well as common power transmission drive components.

The 10-20, 10-20FBC, 20, 20FBB, and 10-40 Electro-Modules are designed to mount to the face of a C-frame motor as noted in Table 1.

## Corresponding NEMA Frame Sizes

EM Size	Old NEMA	New NEMA	Shaft Dia.	C-Face Pilot Dia.
50	56 C	48 Y	5/8	4 1/2
100	56 C	48 Y	5/8	4 1/2
180	182 C	143 TC	7/8	4 1/2
	184 C	145 TC		

Table 1

The 20-30, 20FBC-30 and 30-40 Electro-Modules are designed to mount using a base mounting kit. This allows the modules to be mounted as a separate drive unit driven from the prime mover by V-bolts, chain and sprockets, couplings, timing belts and other standard power transmission components.

The 20FBC series of Electrically Released Brake Modules are designed to be used in clutch-brake combinations. The FBC modules can be mounted on a C-face motor with a (10) input clutch module and can also be foot mounted with a (30) input clutch module and base.

The 20FBB series of Electrically Released Brake Modules are designed to be mounted on the front of a C-faced motor as a brake only.

The Fail Safe (FBB & FBC) brake engages when the power goes off.

(For Electro-Module sizes 210 and 215 please refer to Warner Electric manual P-213.)

Install your specific Electro-Module combination according to the installation steps specified in Table 2. Use only those steps indicated for each combination.

**For these EM combinations:**

**Use Sections:**

	<p>Electro-Module Clutch-Brake Between C-Face Motor and Reducer – 10-20</p> <p>Electro-Module Clutch-Fail Safe Brake Between C-Face Motor and Reducer – 10-20FBC</p> <p>Electro-Module Clutch only Between C-Face Motor and Reducer – 10-40</p>	<p>A, C, G, I, K</p> <p>A, J, G, I, K</p> <p>A, C, G, I, K</p>
	<p>Electro-Module Clutch-Brake – 20-30</p> <p>Electro-Module Clutch-Fail Safe Brake – 20FBC-30</p> <p>Electro-Module Clutch only – 30-40</p>	<p>B, C, G, H, I, K</p> <p>B, J, G, H, I, K</p> <p>B, C, G, H, I, K</p>
	<p>Electro-Module Brake only on C-Face Motor – 20</p> <p>Electro-Module Fail Safe Brake only C-Face Motor – 20 FBB</p>	<p>D, C, H, I, K</p> <p>D, J, H, I</p>
	<p>Motor Mount Electro-Module Brake on C-Face Motor – 20M</p> <p>Motor Mount Electro-Module Fail Safe Brake on C-Face Motor – 20FBB-M</p>	<p>D, C, E, H, I, K</p> <p>D, E, J, H, I</p>
	<p>Motor Mount Electro-Module Clutch Brake on C-Face Motor – 10-20-M</p> <p>Motor Mount Electro-Module Clutch-Fail Safe Brake on C-Face Motor – 10-20FBC-M</p> <p>Motor Mount Electro-Module Clutch only C-Face Motor – 10-40-M</p>	<p>A, C, E, H, I, K</p> <p>A, E, J, H, I, K</p> <p>A, C, E, H, I, K</p>
	<p>Based-Mounted Electro-Module Clutch-Brake – 20-30-B</p> <p>Base-Mounted Electro-Module Clutch-Fail Safe Brake – 20FBC-30-B</p>	<p>B, C, F, H, I, K</p> <p>B, F, J, H, I, K</p>
	<p>Base-Mounted Electro-Module Clutch only – 30-40-B</p>	<p>B, F, C, H, I, K</p>

Table 2

## Section A: Mounting a C-Faced Motor (10-20, 10-20FBC, 10-40)

1. A hardened key is provided with the mounting hardware for the (10) Module. Insert this key onto the motor shaft (staking the key is necessary).
2. Align the keyway in the bore of the (10) Module to the key in the motor shaft and slide the (10) Module onto the motor shaft. The normal alignment of the module to the motor will be with the wire exit upright (12 O'Clock) position as shown in Figure 1.

**⚠ WARNING** Do not hammer or force the module into position. To do so may damage bearings or cause the friction faces to shift out of alignment. Do not tighten the set screws to the motor shaft at this time. This will be done in a later step.

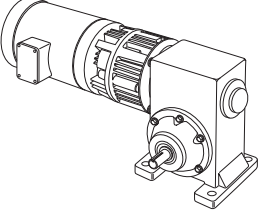
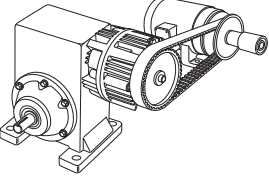
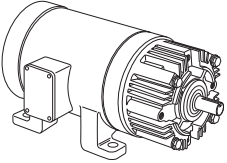
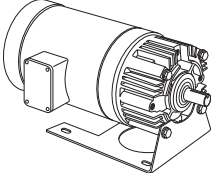
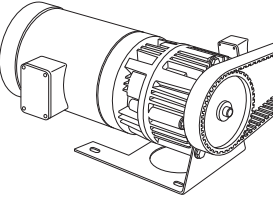
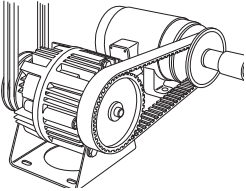
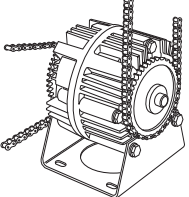

Figure 1

**⚠ CAUTION** If anti-fretting lubricant is used on the motor shaft for future ease of removal, ensure that any excess is wiped off before unit assembly to avoid lubricant contaminating the clutch or brake friction faces.

3. Align the pilot and the mounting holes of the brake module (20 or 20FBC) or if clutch only the module (40) to the pilot and mounting holes of the clutch module (10). The wire exit orientation should match. Secure the modules to the motor with the four (4) long mounting tie-bolts provided. These bolts

pass through the two modules and thread into the motor C-face. Tighten the four (4) bolts alternately to ensure even alignment of the module. Tighten them to 30-35 foot pounds, Figure 2.

**⚠ WARNING** Do not tighten the two (2) clutch rotor set screws to the shaft before tightening the four (4) module tie-bolts. This could cause a preload on the pilot bearing resulting in premature bearing failure.



Figure 2

4. Next, secure the clutch rotor and fan assembly to the motor shaft by tightening the two (2) setscrews as follows:
  - a) There are two (2) access slots on either side of the Module (10). A long Allen wrench can be used to tighten the two setscrews (90% apart) which secure the rotor and fan assembly to the motor shaft.
  - b) Alternately align each setscrew with one of the access slots by rotating the clutch rotor and fan assembly through one of the side vents with a small screw driver taking care not to damage the fan (Figure 3a).

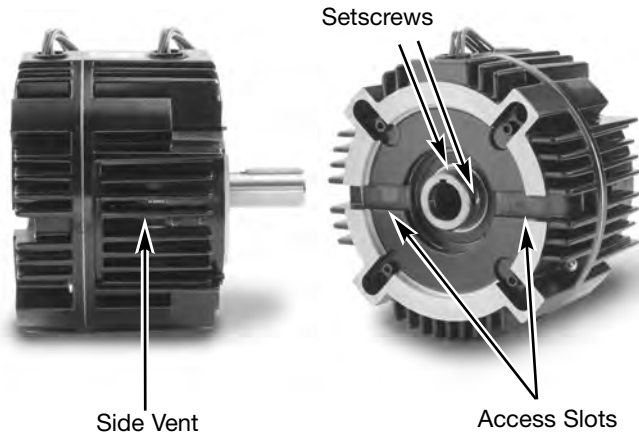

Figure 3a

c) Using a torque wrench and long Allen socket tighten the two (2) setscrews to: (Figure 3b)

- Size 50: 80-85 inch pounds (requires 5/32 inch Allen wrench)
- Size 100 or 180: 40-45 inch pounds (requires 1/8 inch Allen wrench)



Figure 3b

### Section B: Bolting Two Modules Together (20-30, 20FBC-30, 30-40)

The brake module (20 or 20FBC) or output clutch module (40) may be assembled to the input clutch module (30).

1. Align the pilot and mounting holes of brake module (20 or 20FB) or if clutch only the module (40) to the pilot and mounting holes of the clutch module (30). The wire

orientation should match. Secure the modules together with four (4) tie-bolts provided. Tighten the four (4) bolts alternately to ensure even alignment of the modules. Tighten them to 30-35 foot pounds. (Figure 4)



Figure 4

### Section C: Adjusting the Airgap

For new installations it is necessary to adjust the airgap between the friction faces of the clutch and/or brake.

To set the airgap for an Electro-Module (EM) you will need to access the armatures. You will note that there are gaps between the housing fins on both sides of the module. When looking through this gap, you will see the fan on the clutch rotor. On the outer periphery of the fan there is a 1/2 x 1 inch window. It is possible to look inside the module and see the armatures by looking through this window. When looking into the window you will be looking between the two armatures of the clutch or brake. [In a module (10-40) there is only a single armature.] (Figures 5 & 6)

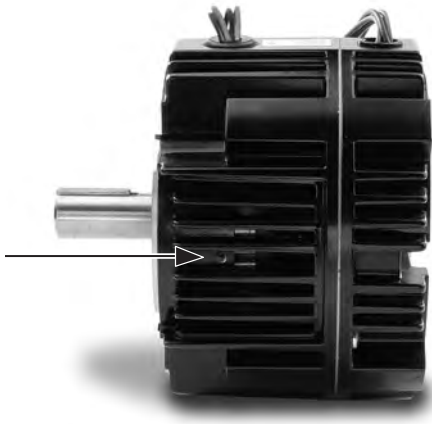

Figure 5

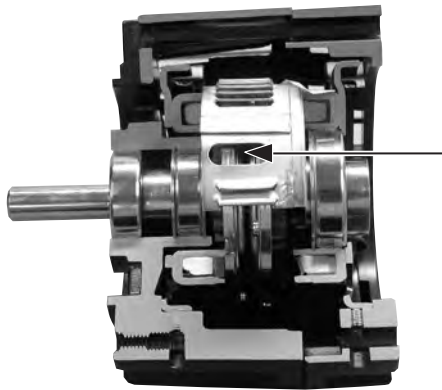

Figure 6

If the armature for either the clutch or the brake is too far away from its mating friction surface, it is possible to move it back into adjustment using a flat blade screwdriver between the two armatures. (Figure 7)

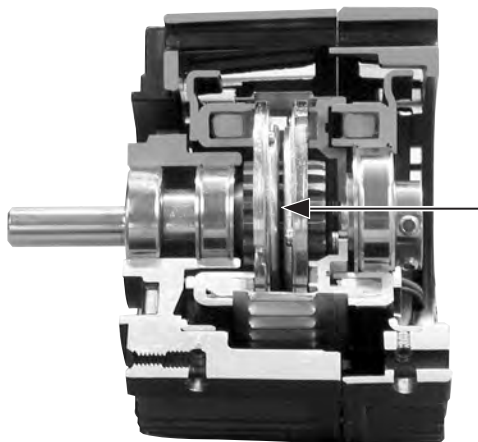

Figure 7

This is a three step process.

1. Simply slide the screwdriver through the window. By twisting the screwdriver, it works as a wedge to apply pressure on the back of the armature pushing it toward its mating friction surface.
2. Rotate the output of the unit. The rotor and window should stay in place when you do this. Only the armatures will move. If you rotate the input of the unit, the rotor and access window will rotate as well.
3. Alternately repeat steps 1 & 2 to ensure that the airgap between the armature and its mating surface is about 1/32 inch and the armature remains square to its mating surface. (If the armature is uneven, it may engage on just one side giving the appearance of engagement but failing to provide full torque.)

If there is a scraping or rubbing sound when the output shaft is rotated, this means that an armature is dragging and is too close to its mating surface. Simply repeat steps 1-3 above, but place the screwdriver between the face of the armature and its mating friction surface and move the armature away from its friction mating surface.

**Note:** If you have a (20FBB, or FBC) Fail Safe Brake Module the airgap is set at the factory and should not need adjusting. The brake setup will be covered during the **FB Brake Release Adjustment Section J.**

**Section D: Mounting the Brake to a Motor (20, 20FBB)**

The brake module (20 or 20FBB) can be mounted directly to a motor.

1. A hardened key is provided with the mounting hardware for the module (20 or 20 FBB). Insert this key onto the motor shaft and prick punch the end of the motor shaft keyway to prevent the key from sliding out.
2. Align the motor shaft and key with the mating shaft hole and key slot in the brake module (20 or 20FBB). (Figure 8)



Figure 8

3. Secure the brake module (20 or 20FBB) to the motor C-face with the four (4) long hex head capscrews provided. Tighten the four (4) bolts alternately to ensure even alignment of the module. Tighten them to 30-35 foot pounds.

**Section E: Installing the Motor Mount Bracket (10-20, 10-20FBC, 10-40, 20, 20FBB)**

A Motor Mount Bracket can be installed on the output end of a module (10-20 or 10-20FBC, 20, 20 FBB) or (10-40) to provide a foot mounting for the complete assembly of an Electro-Module and C-face motor.

Optional Motor Mount Kit,  
 Warner Electric part numbers:  
 EM-50/100.....5370-101-078  
 EM-180.....5370-101-079

1. Mount the bracket to the face of the Electro-Module underneath the Module and Motor as shown in Figure 9. A pilot diameter on the Electro-Module mates with a pilot diameter on the bracket.



Figure 9

2. Secure the motor bracket in place with four (4) short bolts and washers provided. Tighten to 18-22 foot pounds.

**Section F: Installing the Base Mount (20-30, 20FBC-30, 30-40)**

Model (20-30 or 20FBC-30) and (30-40) Electro-Modules are designed to be base mounted as shown in Figure 10.

Optional Base Kit,  
 Warner Electric part numbers:  
 EM-50/100.....5370-101-004  
 EM-180.....5370-101-002



Figure 10

1. The pilot diameters on each end of the Electro-Module will mate with the pilot diameters on the base.
2. Secure the base to the Electro-Module with the four (4) bolts provided. Tighten to 18-22 foot pounds.

### Section G: Mounting to a Reducer (10-20, 10-20FBC, 10-40, 20-30, 20FBC-30, 30-40)

1. Warner Electric Electro-Modules are furnished with a hardened key pre-mounted on the output shaft.
2. Align the output shaft and keyway of the module with the corresponding bore and keyway of the reducer. Slide the assembly together as shown in Figure 11.



Figure 11

3. Bolt the (10-20, 10-20FBC, or 10-40) motor/module or output of a (20-30, 20FBC-30, or 30-40) double shafted module to the reducer flange. The four (4) bolts that are required (3/8-16UNC2A) are typically provided with the reducer. Tighten to 18-22 foot pounds of torque.

### Section H: Mounting on the Input and Output Shafts

**CAUTION** Couplings, pulleys, sprockets or similar power transmission components can be mounted to the input and output shafts of an Electro-Module.

**CAUTION** When mounting a pulley or sprocket, ensure that the key is fully engaged within the device hub or housing.

**Confirm that the belt or chain tightness meets the maximum side load capability of the UniModule shown in Table 3.**

### Overhung Load Data (Shaft Side Load)

Overhung load data is provided in this manual for the design engineer concerned with a specific problem in this area. The maximum allowable overhung load which can be applied to the shaft of an Electro-Module may be determined by the use of the accompanying chart.

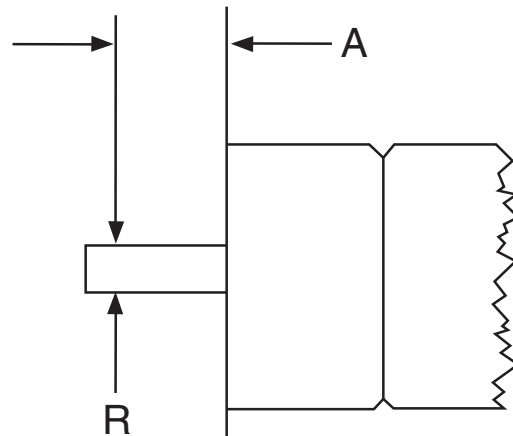



Electro-Module	Distance Load is Applied from Housing Face "A" Inches	Maximum Load Rating "R" Lbs.
EM-50	1" Center of Shaft	177
	2" End of Shaft	123
	3"	95
EM-100	1" Center of Shaft	192
	2" End of Shaft	134
	3"	104
EM-180	1" Center of Shaft	192
	2" End of Shaft	134
	3"	104

Table 3

## Section I: Electrical Connections

**⚠ WARNING** To avoid injury (or even death), always make certain all power is off before attempting to install or service this device or any electrical equipment.

The conduit connection hole in the motor clutch module (10), brake (20, 20FBB or 20FBC), and input clutch (30) are threaded for standard 1/2 inch conduit connection. Electro-Module clutches and brakes operate on DC voltage. Warner Electric offers a complete line of electronic controls to meet the needs of almost any clutch or clutch/brake application. Each Warner Electric control will provide the proper wiring connections for its use.

### Control Requirements for (FB) Fail Safe Brakes

Electrically Released Permanent Magnet Brakes must use one of Warner Electric's adjustable power supplies. See the Service Installation sheet included with the power supply for connection information.

**Note:** All Electrically Released Permanent Magnet Modules are polarity sensitive. Therefore, the (+) red wire must be connected to the positive terminal and the (-) black wire to the negative terminal. Potentiometer control will then provide adjustment for the proper brake release point.

Switching of clutch and (FB) brake with this type of module should allow both clutch and brake to be engaged and disengaged simultaneously for proper operation.

If a Conduit Box is desired, Warner Electric Conduit Box Kit, part number 5370-101-042, can be purchased separately. The Conduit Box provides two conduit connection holes for standard 1/2 inch conduit connectors.

**Note:** If you have a clutch/brake module, you may need two (2) Conduit Box Kits because the clutch wires and brake wires exit from separate holes.

## Section J: FB Brake Release Adjustment (20FBB, 20FBC)

Instructions for setting the optimum release voltage of permanent magnet applied/electrically released brakes.

**⚠ CAUTION** The following procedure will result in the brake releasing and allowing the load to be free to move. Be sure the load is in a safe condition before proceeding with this process.

In a permanent magnet applied/electrically released brake, the attractive force between the brake surfaces is created by permanent magnets. The brake is electrically released by applying DC power to the electro-magnetic coil in the brake that opposes the permanent magnets.

Electrically released brakes are polarity sensitive: the positive lead of the power supply must be connected to the positive (red) lead of the brake and the negative lead of the power supply must be connected to the negative (black) lead of the brake.

The power supply applied to the brake must also be adjustable so that the optimum release voltage for each individual brake can be determined and set.

The following procedure describes how to set the adjustable power supply to the optimum release point of the brake. A volt-meter is required to perform the procedure.

**No power is applied to motor during this procedure. Power normally supplied by motor to brake control should be supplied by alternate method.**

1. With power off, connect the positive (red) lead of the power supply to the positive (black) lead of the brake and the negative lead of the power supply to the negative lead of the brake.
2. Connect a volt-meter to measure the voltage applied across the brake.
3. Adjust the power supply to its lowest possible output, and then energize the power supply to apply power to the brake only.
4. Starting from the low voltage point, slowly increase the applied voltage while visually watching the brake armature through one of the vent slots and fan slot on either side of the module until the brake armature disengages from the brake magnet. Note and record this voltage reading.
5. Add twenty (20) volts for a 90 volt brake and five (5) volts for a 24 volt brake to this reading and set the supply to this level. This will be the proper release voltage for your setup.
6. With the brake energized, spin the output shaft by hand to insure that it turns freely. If a scraping sound is noted when the output shaft is spun, it means an armature is dragging slightly. This needs to be corrected by readjusting the airgap per Section C and/or repeating brake release adjustment steps 1-5 above.

**Note:** If you have a clutch/FB brake, the clutch armature airgap should be adjusted at this time per section C. The brake must be energized/released during the clutch airgap adjustment so the output shaft can be rotated by hand.

## Section K: Burnishing

Intimate metal to metal contact is essential between the armature and the metal rings (poles) of the magnet or rotor. Warner Electric clutches and brakes leave the factory with the friction material slightly undercut to assure good initial contact.

Normally, the desired wearing-in process occurs naturally as the surfaces slip upon engagement. The time for wear-in, which is necessary to obtain the ultimate torque of the unit, will vary depending on speed, load, and duty cycle.

If maximum torque is required immediately after installation, the unit should be burnished by slipping the friction surfaces together at reduced voltage. It is recommended that the burnishing be done right on the application, if at all possible.

Burnishing at high speed will result in a smoother wear-in pattern and reduce the time for burnishing. The voltage should be set at approximately 30% or 40% of the rated value.

The unit should be cycled on and off to allow sufficient time between slip cycles to prevent overheating.

When a Warner Electric brake or clutch is properly assembled and installed, no further servicing, lubrication, or maintenance should be required throughout the life of the unit.

## Troubleshooting - Electrical

A module that is not functioning properly may be caused by other problems. It is best to check for these problems before replacing it.

A standard Electro-Module clutch or brake requires DC power to function. If power is not reaching the clutch or brake, they will not disengage.

A good practice to follow is to check for power at the lead wires to the clutch or brake using a voltmeter.

- If power is present in the proper voltage and current, then skip ahead to the Mechanical Troubleshooting Section.
- If power is not present, inspect the lead wires for breaks or cuts.
- If the wires are intact, the problem may be with the power supply or the switch.
- Using a voltmeter, check to see that voltage is leaving the power supply and that the switch is sending power to the clutch or brake.
- Finally, if there is no power leaving the switch or power supply, check the incoming AC power to insure that it is reaching the power supply.

### Electrical Coil Data

		Clutch	Brake	Clutch	Brake
<b>Voltage-D.C.</b>		<b>90</b>	<b>90</b>	<b>24</b>	<b>24</b>
Resistance (OHMS)	EM-50	452	429	31.8	28.8
	EM-100/180	392	308	26.7	21.7
Current (Amperes)	EM-50	.20	.21	.76	.83
	EM-100/180	.23	.29	.90	1.1
Power (WATTS)	EM-50	18	19	19	20
	EM-100/180	21	27	22	27
Coil Build Up Time (ms)	EM-50	52	40	52	40
	EM-100/180	72	80	72	80
Coil Decay Time (ms)	EM-50	6	5	6	5
	EM-100/180	12	8	12	8

### Troubleshooting - Mechanical

A likely mechanical cause for a clutch or brake not engaging when DC power is applied is that the airgap between the friction faces is too large. When power is applied to an Electro-magnetic clutch/brake, the unit magnetically clamps the friction faces together. An airgap that is too large can keep the unit from clamping together. If the airgap is too small the faces will rub all of the time.

To adjust the airgap, see Section C on page 5.

### Mechanical Data

	EM-50	EM-100/180
Static Torque - lb. ft.	16	30
Maximum Speed - rpm	3600	3600
Average Weight - lbs.		
20	9.2	11.2
10-20	15.6	18.7
10-40	14.0	16.6
20-30	18.4	21.7
30-40	16.8	19.5

Configuration	Inertia - WR - lb.ft. <sup>2</sup>	
	50	100/180
20 output	.0195	.050
10-20 input	.021	.047
10-20 output	.0195	.050
10-40 input	.021	.047
10-40 output	.0105	.027
20-30 input	.021	.047
20-30 output	.0195	.050
30-40 input	.021	.048
30-40 output	.0105	.027

### Enclosed Electro-Module Options

Vented Warner Electric Electro-Module and base assemblies can be oriented as necessary to keep contaminants from entering the open housing vents.

If an Enclosed Electro-Module (10-20, 10-40, 20-30, 30-40, 10-20FBC, 20FBC-30) is required an optional Cover Kit, Warner Electric part number 5370-101-076, can be purchased separately to enclose the open vents in the housing. Each Cover Kit includes two (2) vent covers and four (4) screws needed to convert a vented Electro-Module to an enclosed design (non-washdown) as shown in Figure 12a.

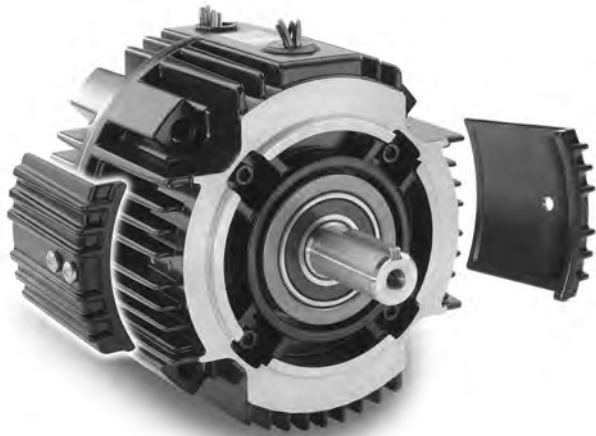

Figure 12a

**Notes:** Visit Warner Electric’s website at [www.warnerelectric.com](http://www.warnerelectric.com) for dimensional drawings, weights, inertia’s and a complete offering of our products including clutches, brakes, and clutch or brake controls and service parts.

In addition, Warner Electric module products, controls and service parts information can be found in our catalog P-1234-WE. Call 815-389-3771 to request any of our catalogs.

If an Enclosed Electro-Module (20 and 20FBB brake only) is required, an optional Cover Kit, Warner Electric part number 5370-101-082, can be purchased separately to enclose the open vents in the housing and a cover plate to close off the back of the Module. Each Cover Kit includes two (2) covers and four (4) screws and one (1) cover plate needed to convert a vented Electro-Module 20 to an enclosed design (non-washdown) as shown in Figure 12b.

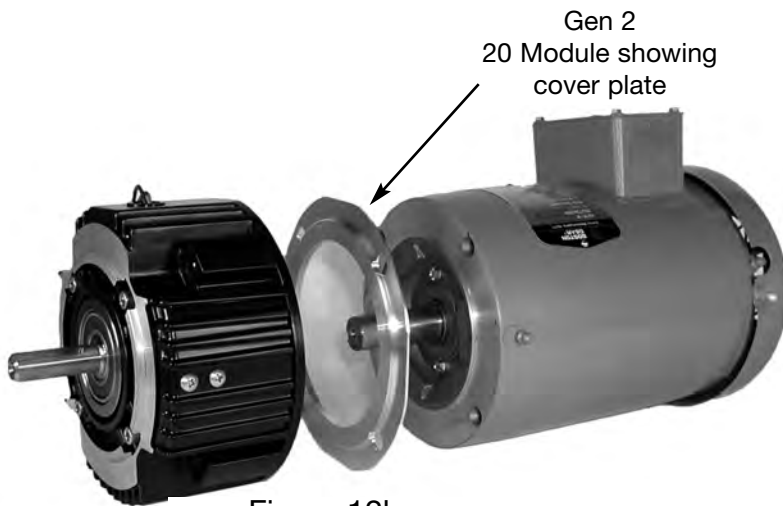

Figure 12b

**Note:** When using these Cover Kits to enclose the module the covers should be assembled as the final step.



MEX (55) 53 63 23 31 MTY (81) 83 54 10 18  
QRO (442) 1 95 72 60 [ventas@industrialmagza.com](mailto:ventas@industrialmagza.com)

## Warranty

Warner Electric LLC warrants that it will repair or replace (whichever it deems advisable) any product manufactured and sold by it which proves to be defective in material or workmanship within a period of one (1) year from the date of original purchase for consumer, commercial or industrial use.

This warranty extends only to the original purchaser and is not transferable or assignable without Warner Electric LLC's prior consent.

Warranty service can be obtained in the U.S.A. by returning any defective product, transportation charges prepaid, to the appropriate Warner Electric LLC factory. Additional warranty information may be obtained by writing the Customer Satisfaction Department, Warner Electric LLC, 31 Industrial Park Road, New Hartford, Connecticut 06057, or by calling 815-389-3771.

A purchase receipt or other proof of original purchase will be required before warranty service is rendered. If found defective under the terms of this warranty, repair or replacement will be made, without charge, together with a refund for transportation costs. If found not to be defective, you will be notified and, with your consent, the item will be repaired or replaced and returned to you at your expense.

This warranty covers normal use and does not cover damage or defect which results from alteration, accident, neglect, or improper installation, operation, or maintenance.

Some states do not allow limitation on how long an implied warranty lasts, so the above limitation may not apply to you.

Warner Electric LLC's obligation under this warranty is limited to the repair or replacement of the defective product and in no event shall Warner Electric LLC be liable for consequential, indirect, or incidental damages of any kind incurred by reason of the manufacture, sale or use of any defective product. Warner Electric LLC neither assumes nor authorizes any other person to give any other warranty or to assume any other obligation or liability on its behalf.

WITH RESPECT TO CONSUMER USE OF THE PRODUCT, ANY IMPLIED WARRANTIES WHICH THE CONSUMER MAY HAVE ARE LIMITED IN DURATION TO ONE YEAR FROM THE DATE OF ORIGINAL CONSUMER PURCHASE. WITH RESPECT TO COMMERCIAL AND INDUSTRIAL USES OF THE PRODUCT, THE FOREGOING WARRANTY IS IN LIEU OF AND EXCLUDES ALL OTHER WARRANTIES, WHETHER EXPRESSED OR IMPLIED BY OPERATION OF LAW OR OTHERWISE, INCLUDING, BUT NOT LIMITED TO, ANY IMPLIED WARRANTIES OF MERCHANTABILITY OR FITNESS.

Some states do not allow the exclusion or limitation of incidental or consequential damages, so the above limitation or exclusion may not apply to you. This warranty gives you specific legal rights and you may also have other rights which vary from state to state.

### **Changes in Dimensions and Specifications**

All dimensions and specifications shown in Warner Electric catalogs are subject to change without notice. Weights do not include weight of boxing for shipment. Certified prints will be furnished without charge on request to Warner Electric.



**Warner Electric**  
31 Industrial Park Road • New Hartford, CT 06057 - USA  
815-389-3771 • Fax: 815-389-2582  
[www.warnerelectric.com](http://www.warnerelectric.com)